

Product availability : Non-Stock - Not normally stocked in distribution facility



Main

Range of product	Modicon Power Supply
Product or component type	Power supply
Power supply type	Regulated switch mode
Variant option	Optimized
Enclosure material	Aluminum
Nominal input voltage	100...240 V AC single phase 100...240 V AC 2 phases 140...340 V DC
Input voltage limits	85...264 V AC 120...375 V DC
Rated power in W	120 W
Output voltage	48 V DC
Power supply output current	2.5 A

Complementary

Nominal network frequency	50...60 Hz
Network system compatibility	TN TT IT
Maximum leakage current	1 mA 240 V AC
Input protection type	Integrated fuse (not interchangeable) 4 A External protection (recommended) 20 A Curve C External protection (recommended) 13 A Curve C
Inrush current	30.0 A 115 V 60.0 A 230 V
Power factor	0.55 at 115 V AC 0.45 at 230 V AC
Efficiency	85 % 115 V AC

* Price is "List Price" and may be subject to a trade discount – check with your local distributor or retailer for actual price.

	88 % 230 V AC
Output voltage adjustment	44...56 V
Power dissipation in W	23 W
Current consumption	< 2.5 A 115 V AC < 1.4 A 230 V AC < 1.3 A 140 V DC
Turn-on time	< 1 s
Holding time	> 20 ms 115 V AC > 40 ms 230 V AC
Startup with capacitive loads	4000 µF
Residual ripple	< 150 mV
Expected capacitor life time	10 year(s)
Meantime between failure [MTBF]	700000 h at 25 °C, full load conforming to SR 332
Output protection type	Against overload and short-circuits automatic reset Against over temperature manual reset Against overvoltage manual reset
Connections - terminals	Screw connection 0.5...4 mm ² , AWG 20...AWG 12) without wire end ferrule output Screw connection 0.5...2.5 mm ² , AWG 20...AWG 14) with wire end ferrule output Screw connection 0.75...4 mm ² , AWG 18...AWG 12) without wire end ferrule input Screw connection 0.75...4 mm ² , AWG 18...AWG 12) with wire end ferrule input
Line and load regulation	< 0.5 %line < 1 %load
Status LED	Output voltage 1 LED Green)
Depth	4.63 in (117.6 mm)
Height	4.87 in (123.6 mm)
Width	1.57 in (40 mm)
Net Weight	1.21 lb(US) (0.55 kg)
Output coupling	Parallel
Mounting support	Top hat type TH35-15 rail IEC 60715 Top hat type TH35-7.5 rail IEC 60715 Double-profile DIN rail

Environment

Standards	EN 62368-1 EN/IEC 61204-3 EN 61000-6-1 EN 61000-6-2 EN 61000-6-3 EN 61000-6-4 EN 61000-3-2 EN 61000-3-3 UL 62368-1 CSA C22.2 No 62368-1 UL 508 CSA C22.2 No. 107.1
Product certifications	CE CUL Listed CUL Recognized RCM CB Scheme EAC KC
Environmental characteristic	3M4 IEC 60721-3-3
Operating altitude	< 5000 m
Shock resistance	100 m/s ² 11 ms
IP degree of protection	IP20
Ambient air temperature for operation	-4...14 °F (-20...-10 °C) with current derating of 2 % per °C) 104...158 °F (40...70 °C) with current derating of 1.8 % per °C) 122...158 °F (50...70 °C) with current derating of 2.5 % per °C)
Ambient air temperature for storage	-40...185 °F (-40...85 °C)
Relative humidity	0...95 % without condensation
Overvoltage category	II

Electrical shock protection class	Class I
Pollution degree	2
Vibration resistance	3 mm 2...9 Hz)IEC 60068-2-6 10 m/s ² 9...200 Hz)IEC 60068-2-6
Electromagnetic immunity	Immunity to electrostatic discharge 6 kV contact discharge) EN/IEC 61000-4-2 Immunity to electrostatic discharge 9 kV air discharge) EN/IEC 61000-4-2 Immunity to conducted RF disturbances 10 V/m 80 MHz...2 GHz) EN/IEC 61000-4-3 Immunity to conducted RF disturbances 5 V/m 2...2.7 GHz) EN/IEC 61000-4-3 Immunity to conducted RF disturbances 3 V/m 2.7...6 GHz) EN/IEC 61000-4-3 Immunity to fast transients 4 kV on input-output) EN/IEC 61000-4-4 Surge immunity test 3 kV between power supply and earth) EN/IEC 61000-4-5 Surge immunity test 1.5 kV between phases) EN/IEC 61000-4-5 Immunity to conducted RF disturbances 10 V 0.15...80 MHz) EN/IEC 61000-4-6 Immunity to magnetic fields 30 A/m 50...60 Hz) EN/IEC 61000-4-8 Immunity to voltage dips EN/IEC 61000-4-11 Disturbing field emission EN 55016-2-3 Limits for harmonic current emissions EN 61000-3-2 Conducted disturbance emission EN 55016-1-2 Conducted disturbance emission EN 55016-2-1
Electromagnetic emission	Conducted emissions EN 61000-6-3 Radiated emissions EN 61000-6-4
Dielectric strength	3000 V AC input to output

Ordering and shipping details

Category	22525 - ABL8 AND ABL7 POWER SUPPLIE
Discount Schedule	CP12
GTIN	03606481500243
Nbr. of units in pkg.	1
Package weight(Lbs)	1 lb(US) (0.45 kg)
Returnability	Yes

Offer Sustainability

Sustainable offer status	Green Premium product
REACH Regulation	REACH Declaration
EU RoHS Directive	Pro-active compliance (Product out of EU RoHS legal scope) EU RoHS Declaration
Mercury free	Yes
RoHS exemption information	Yes
China RoHS Regulation	China RoHS declaration
Environmental Disclosure	Product Environmental Profile
Circularity Profile	End of Life Information
WEEE	The product must be disposed on European Union markets following specific waste collection and never end up in rubbish bins.

Electrical Safety

- If the unit is use in a manner not specified by the manufacturer, the protection provided by the equipment may be impaired.
- For means of disconnection a switch or circuit breaker, located near the product, must be included in the installation. A marking as disconnecting device for t
- The device has an internal fuse. The unit is tested and approved with branch circuit protective device up to 20A. This circuit breaker can be used as disconn
- The power supply is only suitable for audio, video, information, communication, industrial and control equipment.

Dimensions

Front and Side Views

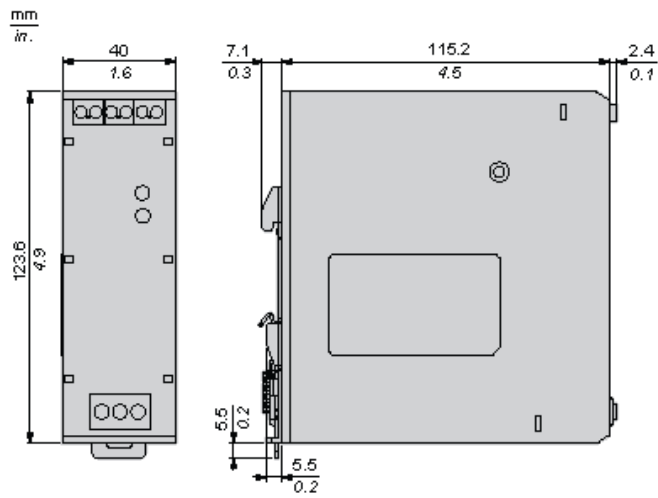

Connections and Schema

Correct Parallel Connection

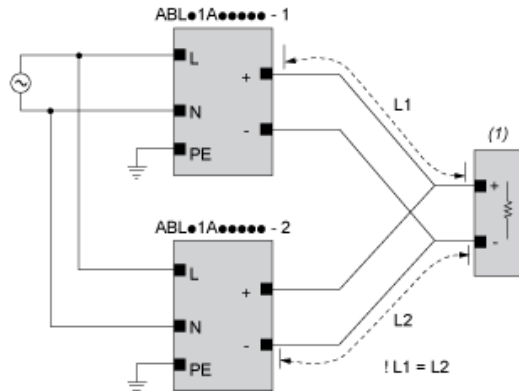

(1): Load

Incorrect Parallel Connection

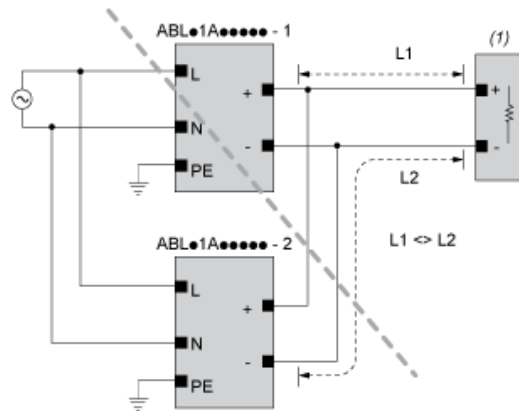

(1): Load

$ABLx1Axxxxx-1 = ABLx1Axxxxx-2$

max 2 x ABLx1Axxxxx

$L1 = L2$

ΔV max 25 mV

$L_{Load} < 90\% \cdot 2 \cdot L_{nom}$

Output Voltage Balancing

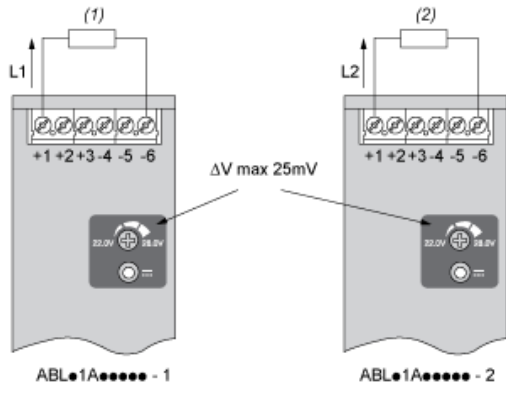

(1) : R_{Load1}

(2) : R_{Load2}

$R_{Load1} = R_{Load2}$

$I_1 = I_2 \approx I_{nom}$

Series Connection

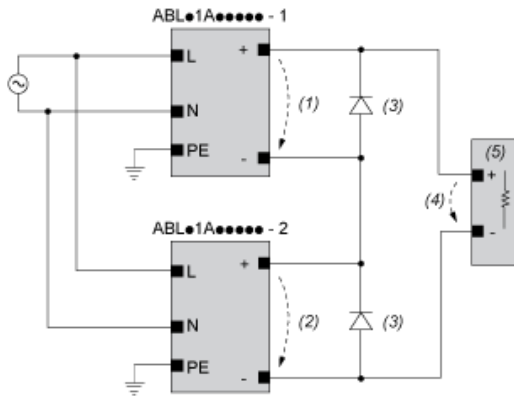

(1) : V_{out1}

(2) : V_{out2}

(3) : $2 \times \text{Diode}, V_{RRM} > 2 \times V_{out1/2}, I_F > 2 \times I_{nom1/2}$

(4) : $V_{Load} = 2 \times V_{out}$

(5) : Load

Connections and Schema

	(1)		
	<40°C	<50°C	<70°C
ABLS1A24021	50°C	60°C	75°C
ABLS1A24038	50°C	60°C	75°C
ABLS1A12062	50°C	60°C	80°C
ABLS1A24031	50°C	60°C	80°C
ABLS1A12100	60°C	70°C	90°C
ABLS1A24050	60°C	70°C	90°C
ABLS1A48025	60°C	70°C	90°C
ABLS1A24100	60°C	70°C	90°C
ABLS1A24200	95°C	95°C	90°C

(1): Ambient

Performance Curve

Mounting Position A

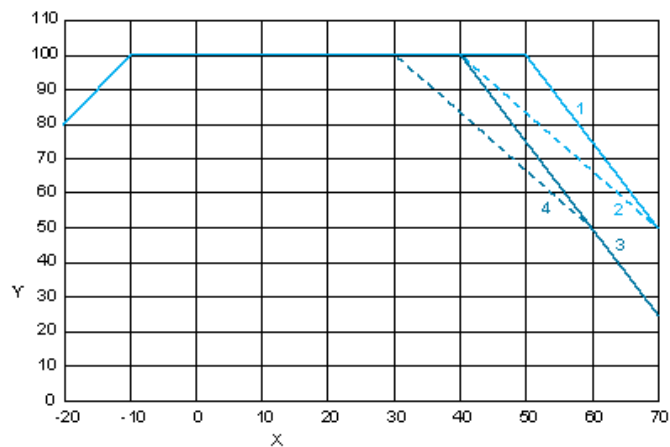

Mounting Position B

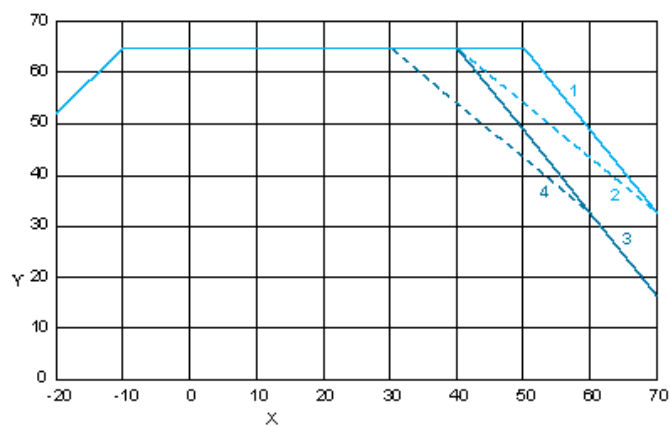

- X : Surrounding Air Temperature
- Y : Percentage of Max Load (%)
- 1 : Altitude 2000m, Input voltage = 230 VAC / 325 VDC
- 2 : Altitude 2000m, 115 VAC / 162 VDC
- 3 : Altitude 5000m, Input voltage = 230 VAC / 325 VDC
- 4 : Altitude 5000m, 115 VAC / 162 VDC

Mounting

Mounting Position A

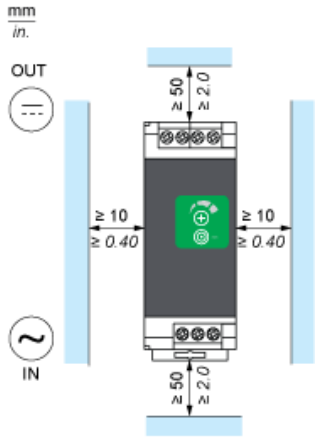

Mounting Position B

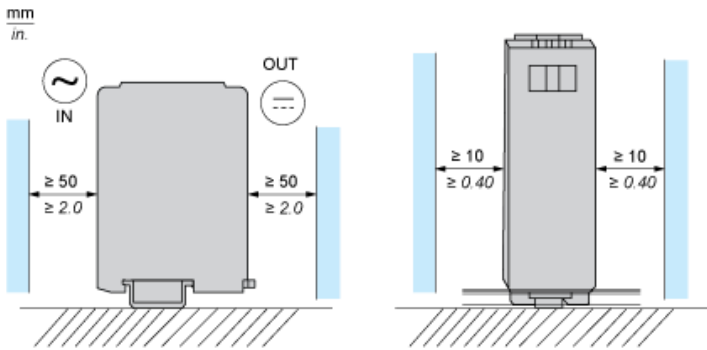

Incorrect Mounting

